

#### (4) Mix your Muesli

*MixYourMuesli*, an online shop has specialized in individually customizing muesli, promising the customer to be able to deliver their favourite muesli mix within 24 hours.

*MixYourMuesli* has a sophisticated website, where customers can select their own individual muesli out of different ingredients. They have to fill in a web-form and submit their completed order to *MixYourMuesli*. After *MixYourMuesli* receives the order, John, the product representative checks whether the selected ingredients can make up a nice and tasty muesli. The decision is made based on his own experience. In case he thinks the customer's muesli selection would taste too bad the customer will be immediately informed by email. This will also result in terminating the process. However, if John thinks that the customer's choice will be tasty, the order can go ahead and the customer will be invoiced straight away by the accounts team. At the same time, the production of the muesli will be started: Normally, Mike or another member of the production team will arbitrarily mix ingredients, such as flakes, apples, raisins and other extras together. When finished, the muesli will be packed, and as soon as the invoice has been paid, the muesli will be sent out to the customer, who can then enjoy his muesli. The production team is also in charge of packing and sending.

In some cases ingredients are not available, or there are other reasons why the muesli cannot be produced within 24 hours. Then, one of the employees gets into the warehouse and selects the pre-packed muesli as substitute that is most similar to the customer's selection. The next step is to notify the customer that only a substitute can be delivered. The customer only needs to respond if he is not happy with the pre-packed muesli. However he then needs to reply by email within 18 hours, otherwise *MixYourMuesli* continues with delivering the muesli.

Quite often, the customer doesn't pay immediately, so after 36 hours *MixYourMuesli* needs to send a reminder. A maximum of two reminders are sent. If the invoice still hasn't been paid the order will be cancelled. Mike will label the freshly mixed muesli as pre-packed, update the database and store it in the warehouse for future use.

**Required:**

Model this process with the help of BPMN 2.0. Please model the process ONLY from the perspective of the company (*MixYourMuesli*). Use as many symbols you think are necessary to model the process as detailed as described in the background.

# MixYourMuesli company view

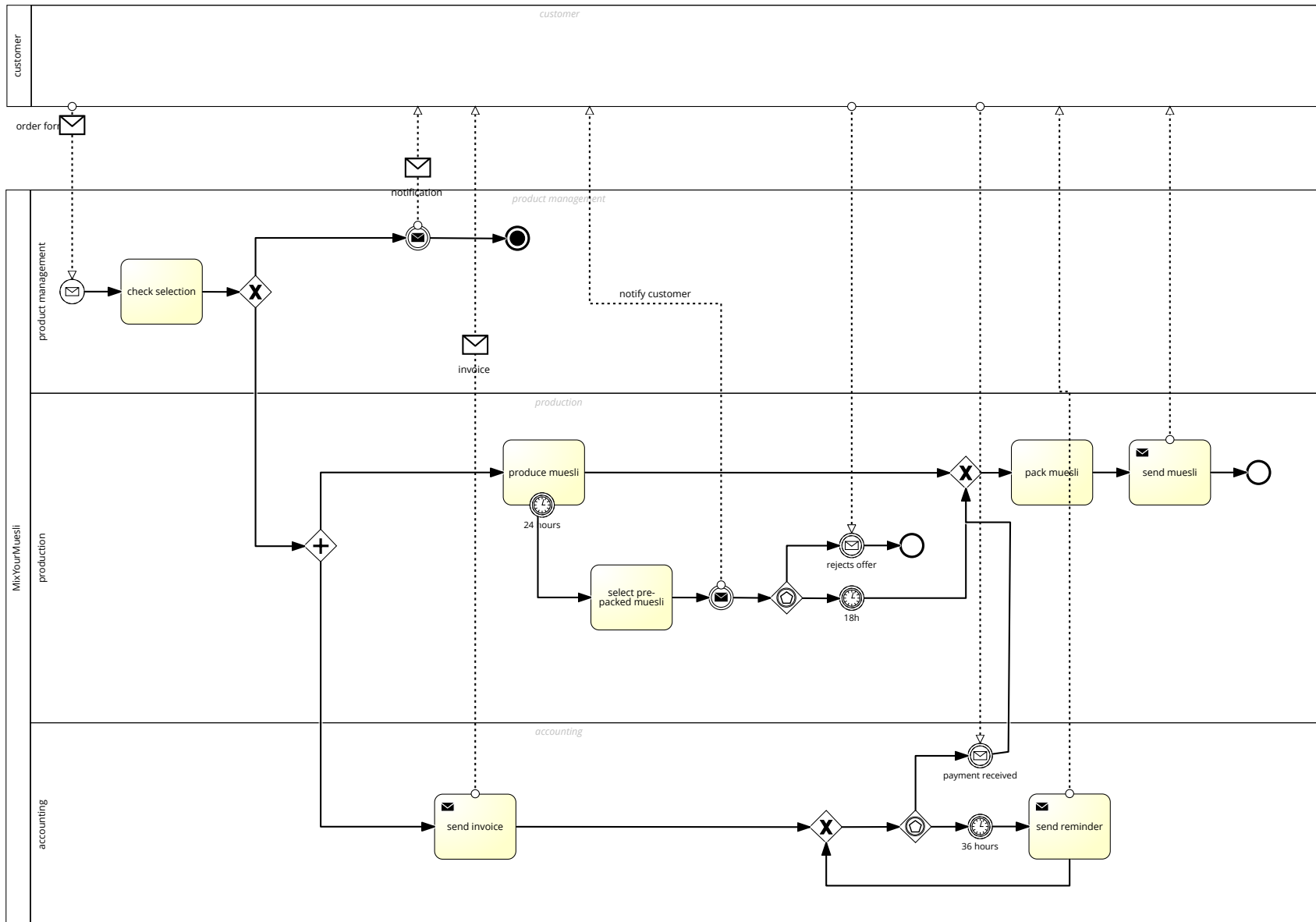

# MixYourMuesli customer view

